

Taconite Duty Sealing System

Ultimate Contamination Protection: The SKF sealed spherical roller bearing creates a fully closed environment, shielding the bearing from contamination and ensuring reliable performance in harsh conditions.

Built for the Toughest Conditions: With the SKF Taconite Duty Sealing System and Three Barrier Solution protection, these bearings are made to thrive in extreme environments where reliability matters.

Long-term Performance: Extended service life, excellent storage protection and standard housings.

Compact. Clean. Maintenance Free: Narrower width, easy installation with no risk of contamination and sealed for life.

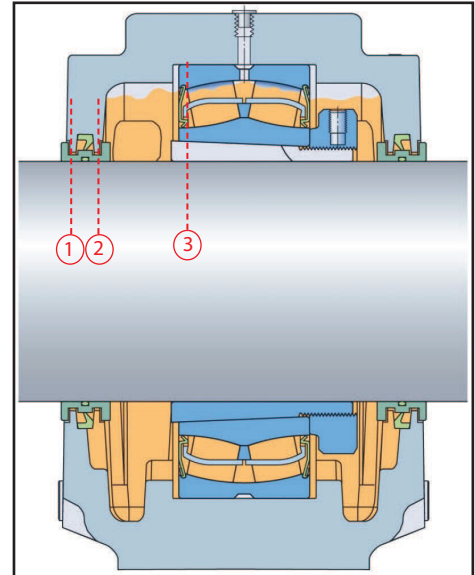

Barrier 1 - SKF housing with SKF external labyrinth seal.

Barrier 2 - 100% grease fill in the housing cavity.

Barrier 3 - SKF Sealed Explorer spherical roller bearing.

Classic Taconite Seal Arrangement with Open Bearing



Contaminated red grease has gone through the bearing on the right side.

SKF Taconite Duty Sealing System with Sealed Bearing

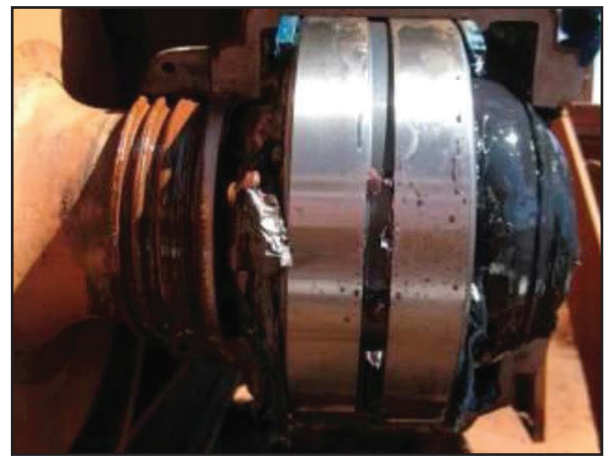

No contamination has gone through the bearing, fresh blue grease on the right side.